



# PSI Process & Equipment



A Division Of  
**Pumping Services, Inc.**  
An Employee Owned Company



**BRENTWOOD INDUSTRIES, INC.**  
brentwoodindustries.com  
polychem@brentw.com  
+1.610.374.5109



CHAIN & FLIGHT SCRAPER SYSTEMS



# Polychem Chain & Flight Scraper Systems

Brentwood has vast experience with sludge collector systems for rectangular clarifiers and is involved in every stage of the process from preliminary design to commissioning. Today, Brentwood has over 18,000 scraper systems and more than 10 million feet of collector chain in operation for various water and wastewater treatment applications. Polychem chain and flight collectors are comprised of the finest quality components available in today's market and with the exception of hardware, all submerged equipment is non-metallic. Reliably constructed and economically designed, these products function efficiently as part of any rectangular clarifier system.



## Strong Yet Lightweight

### NCS-720-S COLLECTOR CHAIN

Precision molded from glass-reinforced polyester, this non-metallic collector chain is designed to withstand high sludge loadings in corrosive environments.

## Simple to Install

### STUB SHAFTS

Our cast nylon stub shafts do not corrode or rust like metal shafting. Intended for use with Polychem idler sprockets, the slide-on design makes installation quick and easy.



## Long-Lasting Solution

### FRP FLIGHTS

Available in a wide range of profiles, fiberglass flights are a cost-efficient, non-buoyant scraping solution.

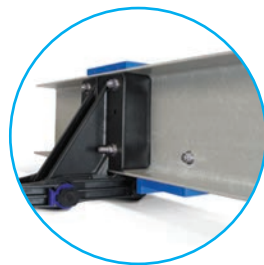

## Durable Supports & Guides

### WEAR STRIPS & RETURN TRACK

Nylon wall brackets, fiberglass return rails, and self-lubricating UHMW-PE wear strips provide low-friction guides and supports for flights.



## Robust Power

### DRIVE UNIT

Brentwood's drive unit assemblies are custom configured for each collector based on system requirements and regional and environmental conditions.

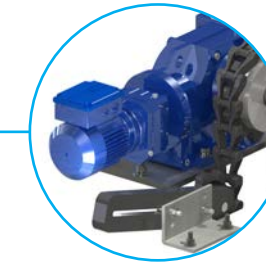

## Ultimate Protection

### SMARTGUARD MONITORING

The SmartGuard® Collector Monitoring System identifies flight misalignment and sprocket motion loss to prevent system damage.



## Telescoping Innovation

### NON-METALLIC HEAD SHAFTS

The unique, lightweight assembly does not require any painting or cranes for installation and is virtually maintenance free.

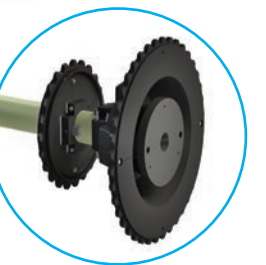

# Collector Chain

Polychem non-metallic chain was introduced in the late 1970s as an alternative to heavy, corrosion-prone chains traditionally used in chain and flight systems. Durably designed to withstand harsh, corrosive environments, Brentwood's non-metallic components provide a strong, lightweight alternative to cast iron and steel systems. Our chains are regularly tested for ultimate strength, proof loading, elongation, and estimated wear life to uphold Brentwood's high quality standards.



## NCS-720-S COLLECTOR CHAIN

Precision molded from durable, glass-reinforced polyester, this robust collector chain is designed to withstand high sludge loadings in severe applications. The specially formulated material and reinforcing ribs prevent elongation to optimize system performance and extend the lifetime of the installation. No special tools are required for installation.

### Components

#### CONNECTING PIN & RETAINING CLIP

- Patented "twist-snap" pin and clip design is easy to install.
- Locking T-heads prevent pin rotation.
- Contrasting color clips minimize field inspection.



### Options

#### BARREL WRAP

- Increases chain life by reducing barrel wear.
- Made of durable, 301 SS for high grit conditions.
- Available in 316 SS for highly caustic conditions.

## Accessories



#### ATTACHMENT LINKS

These links connect the flights to the NCS-720-S strands and are integrally molded in one piece from the same material as the collector chain.



#### WEAR SHOES

Carrying wear shoes run on the collector floor wear strips and return shoes run on the return rail wear strips.



#### FILLER BLOCKS

Filler blocks are rigid spacers between the back of the flight and the attachment link.

# Fiberglass Flights

Brentwood offers more flight scraper options than any other chain and flight manufacturer, enabling us to provide sludge collection solutions for any water or wastewater application. Flights are chosen for each project based on a calculation of tank dimensions, sludge loadings, and budget considerations. All flights integrate with chain-to-flight attachment links and can be equipped with squeegees and wipers for thorough tank cleaning.



#### C-CHANNEL

The preferred choice for normal tank spans and loadings, Brentwood's C-Channel Series has the highest stiffness factor of all standard c-channel designs. These flights can also be used as return rail for added strength and system flexibility.



#### ULTRA

The Ultra Series is designed to handle wider tank spans than C-Channel Flights. With deep legs and vertical ribs parallel to the front face, the profile is stiffer, stronger, and capable of handling higher sludge loadings.



#### BOX

The Box Series' robust profile produces an exceptional stiffness factor, making it one of the sturdiest flights on the market today. Available end caps prevent sludge from accumulating in the box cavity.



#### BRIDGE

The Bridge Series was designed as an option for processes that require a taller scraper flight within a typical collector width. This flight option reduces cost and installation time by accommodating deeper sludge blankets.

## RETURN TRACK & WEAR STRIPS

Brentwood's return track and wear strips are integral parts of our non-metallic chain and flight systems and can be used in both new and existing rectangular sludge collectors. These lightweight components provide a cost-efficient alternative to steel systems and have the strength and durability to support all combinations of chain and flight materials.



#### RETURN TRACK

Polychem return track is manufactured from corrosion-resistant FRP, making it easy to install and field-modify. Return track is supplied in 10-foot (3 m) increments with glass-reinforced Nylon 6-6 wall brackets.

#### WEAR STRIP

Polychem wear strips are the ideal low-friction riding surface for wear shoes. Wear strips are available in both standard and slide-on models.

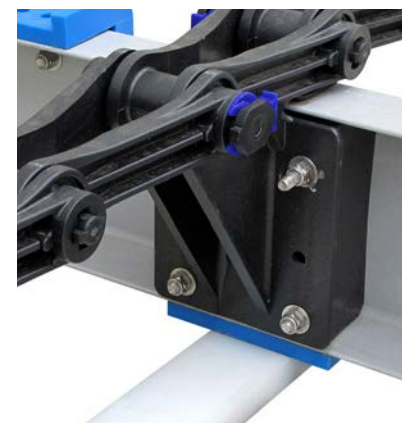

# Head Shaft

The greatest innovation of the first 100 percent non-metallic Polychem chain and flight collector system was the fiberglass telescoping tube head shaft assembly. The unique assembly does not require crane installation and is virtually maintenance free, eliminating the issues typically found with heavy, corrosion-prone steel shafts and bearings. Since its introduction in the 1980s, over 12,000 systems have been successfully supplied using our non-metallic head shaft design.



## FRP TELESCOPING SHAFT

Two fiberglass end tubes with internal bearings and keyways overlap a center tube and are joined together with torque interlocks and set collars to form one robust, easy-to-lift shaft.

## HEAD SHAFT SPINDLES

Mounted to the tank walls these supports allow the FRP shaft to rotate on the spindle journals, and provide a larger bearing surface than traditional metal shafting.

# Stub Shaft

Polychem idler stub shafts are the lightweight alternative to traditional full-width steel shafting and cast iron wall bearings. The non-metallic solid sprockets provide a slide-on alternative that eliminates the need for static sleeve bearings and split sprockets requiring assembly. Available in two base diameters and lengths to accommodate a range of sprocket centerlines, stub shafts can be customized for various tank sizes, system loadings, and existing structural conditions.



## Features

- Engineered to maintain strength and minimize deflection.
- Laterally adjustable up to 2 inches (5 cm) in-field to accommodate structural irregularities.
- Intended for use with Brentwood's solid idler sprocket for simple slide-on installation.
- Includes thermally integrated UHMW-PE bearings which are replaceable to extend service life.

# Sprockets

Polychem sprockets are molded from a specially selected, high-strength Nylon material, allowing them to outwear and outlast UHMW-PE and polyurethane sprocket alternatives. All sprockets are equipped with standard integral teeth to maintain tooth alignment, and head shaft sprockets are furnished with a machined keyway and setscrews in the bore.

## COLLECTOR HEADSHAFT SPROCKET

The hunting-tooth profile design of the NCS-720-S collector sprocket features an odd number of teeth at half the chain pitch, giving sprockets twice the life of full-tooth designs. The split design allows for use with full-width-span shafting and simplifies installation. The integrally molded chain-saver rim decreases chain and sprocket wear. Keyways and setscrews are provided as standard to prevent slippage and to ensure proper torque transmission.



## IDLER COLLECTOR SPROCKET

The solid idler sprocket slides onto Polychem's stub shaft for quick and easy installation and is held in place with a retainer plate. No sprocket hardware or static sleeve bearings are required. Idler sprockets are available with magnets to integrate with SmartGuard sprocket motion sensors, and the integrally molded chain-saver rim decreases chain and sprocket wear.



## DRIVEN SPROCKET

The NH-78 Bull Gear driven sprocket is standardly furnished with 40 integral teeth and designed for use with the NH-78 drive chain. The Polychem driven sprocket is one third the weight of bull gears with cast iron hubs. It is available in a variety of offsets to accommodate the head shaft spindle base and different tank requirements.



# Drive Units

Brentwood's drive units are custom configured for each collector based on system requirements and regional and environmental conditions. Each system may require any or all of the following components, available in a variety of sizes and features depending upon the demands of the application.

## MOTOR & REDUCER

Motors are typically furnished preassembled with the gear reducer. Available with chain guard for operator safety.

## CHAIN TIGHTENER

Tightener systems remove drive chain slack by maintaining proper tension and smooth power transitions. The adjustable, deck-mounted chain tightener assembly consists of a non-metallic bracket, tension arm, and 7-tooth nylon sprocket.

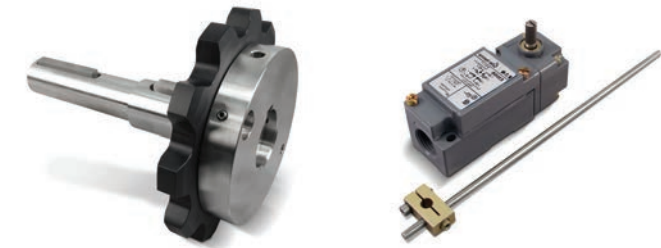
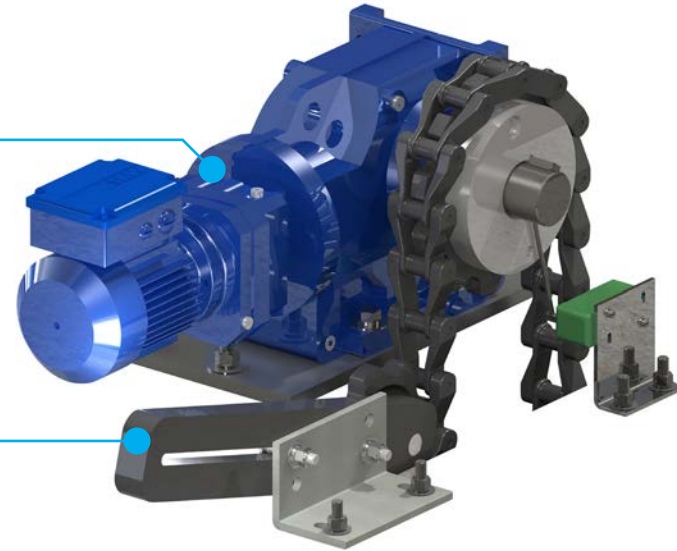

## OVERLOAD PROTECTION

All drive units are furnished with a cast nylon drive sprocket and stainless steel shear pin hub assembly for overload protection. The aluminum necked-down shear pins are kept in place with setscrews to maintain correct alignment, and upon overload, the stainless steel trip pin actuates a limit switch to prevent system damage. A retainer ring is utilized for quick assembly and disassembly.

## DRIVE CHAIN

Brentwood's Polychem NH-78 Drive Chain is used to drive chain and flight collectors, screw conveyors, flocculators, and a range of other low-speed applications. Injection molded from glass-reinforced nylon, NH-78 is strong, lightweight, and resistant to corrosion and chemical damage. This non-metallic replacement for heavy metal chains is simple to install and maintain.



## Components

### CONNECTING PIN

- Knurled end pin allows for ease of installation and disassembly by hand.
- Machined from corrosion-resistant 303 SS.
- Pin sleeve reduces wear and keeps out grit.



## Options

### BARREL WRAP

- Increases chain life by reducing barrel wear.
- Made of durable, 301 SS for high grit conditions.

# SmartGuard® Collector Monitoring System

The SmartGuard® Collector Monitoring System for rectangular clarifiers identifies collector system overloads that cannot be detected by traditional shear-pin or torque monitoring devices. SmartGuard's strategic placement allows it to monitor regular motion, warn of potential danger, and shut down the system before damage can occur. This cost-effective, early detection approach helps water and wastewater plants to avoid costly system failures by controlling up to four mechanisms, including longitudinal collectors, cross collectors, scum pipes, and screw conveyors.

## Features

- Gives you peace of mind by preventing damage to chains, flights, and attachment links.
- Protects against costly system failures that can be caused by irregular sludge loadings, flight misalignment, concrete movement, and foreign objects dropped into the clarifier.
- Simple to use and install.
- Offers reliable system intelligence.
- Monitoring systems available for sprocket motion monitoring, flight misalignment, or both.



## SPROCKET MOTION MONITORING

Sensors placed at the lower-rear idlers monitor sprocket motion and automatically shut down the system if motion loss occurs.



## FLIGHT MONITORING

Flight alignment information is gathered by two cams that are tripped as flights pass over the head shaft.

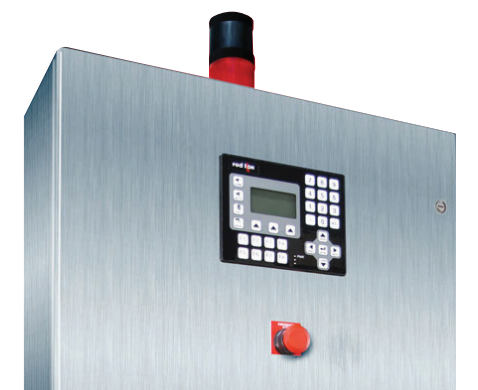

## CONTROL PANEL

Available with adaptable control panel that either complements existing control systems or functions as a total control solution.

# Collector Systems

Brentwood's team of engineers and sales personnel have the necessary knowledge and experience to help customers with projects of any size and scope. Operating in clarifiers up to 300 feet (91 m) long and 40 feet (12 m) wide, as well as in heavy-duty stacked clarifiers, Brentwood's top-quality Polychem products and components continue to produce field-proven results by handling the most severe sludge-loadings and complex tank geometries. Typical tank configurations include:

## 3-SHAFT COLLECTOR



## DISSOLVED AIR FLOTATION TANK

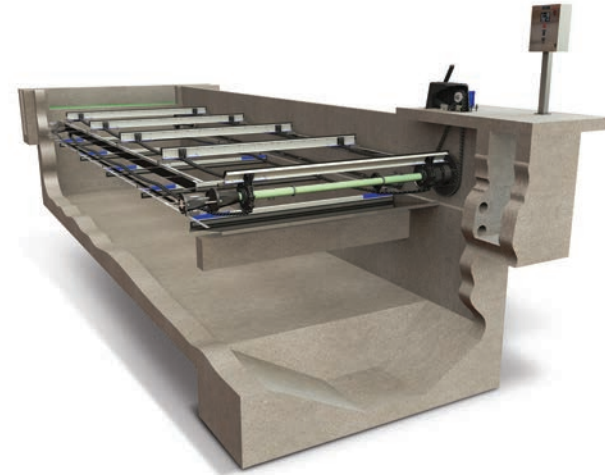

## 4-SHAFT COLLECTOR



## CROSS COLLECTOR

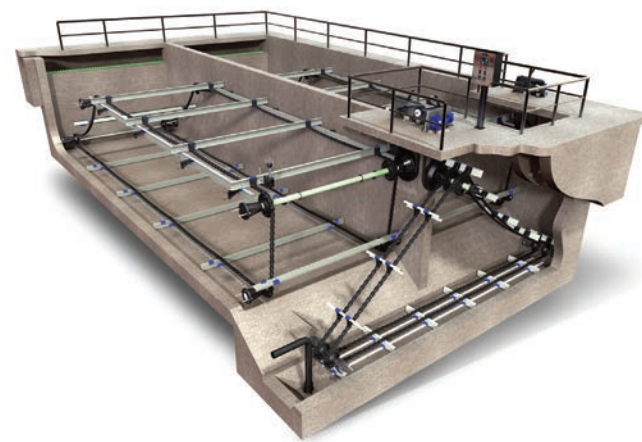

# Brentwood Capabilities

At Brentwood, it's our job to make sure that every customer receives the best solution for their treatment needs. All Polychem systems are supplied in accordance with ISO 9001 quality standards, and components can be NSF 61 certified for drinking water applications. In addition to our quality assurance procedures, our dedication to customer service is evident in every step of the process, from component and system design to installation support and fulfillment. Equipment for every project is consolidated in our warehouse for inspection, in-house testing, and packaging. Our Smart Packaging approach groups like components together to make sure that the items needed first are easily accessed. Each crate, box, and pallet is labeled with quantity and part numbers that correspond to the customers' bills of material for ease of identification at the job site.

## ENGINEERING & PROCESS DESIGN

Brentwood's full staff of technical designers and skilled engineers take each project from concept to realization. Our designers provide installation and layout drawings while working in conjunction with our engineers to perform process analyses and optimize systems for each application; the analyses include calculations for system loads and shaft and flight deflection. Based on these results, recommendations can be given for tank sizing and equipment.

The experience of our engineers is a key factor in product improvement and new product development. Feedback from customers and knowledge gained from installations are assimilated into the design process to ensure that Polychem products and systems address every customer need.

## TECHNICAL SUPPORT

Brentwood's support extends through the entire project scope to system installation and future planning. Our team of field service technicians will assist with startup, testing, and commissioning of Polychem clarification systems. Additionally, our field service personnel can supervise installation, assist with troubleshooting system issues, and make recommendations based on system analysis.

The Component Analysis and System Evaluation (CASE) program, developed by Brentwood, helps customers to prevent problems with their chain and flight equipment and to extend the lifetime of their installations. The specialized tools and software provide facilities with cost-effective recommendations for budgeting future capital expenditures, maintaining inventory levels, and scheduling preventative maintenance.

## AFTERMARKET SERVICES

With thousands of installations worldwide, decades of experience, and innovative product development, Brentwood's aftermarket support service ensures optimal operation at your facility. Our warehouse maintains a large inventory of standard components for quick turnaround, all of which are held to Brentwood's high quality standards. For retrofits and upgrades, we evaluate existing footprints and systems in order to recommend cost-effective, time-saving solutions that will meet needs of increased treatment capacity and efficiency. Our goal is to turn what you have into what you need to meet the demands of tomorrow.